

MC0824-01

Φ8mm Brushless Coreless Motor

Key Features

- Two magnetic pole
- 5.8W
- 25500rpm
- 0.85mNm



Dimensional Drawing

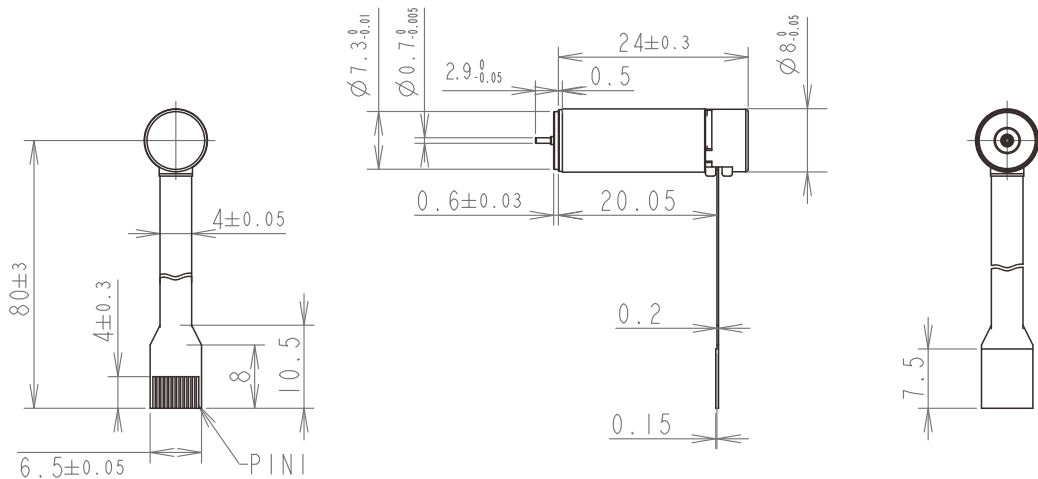

Motor Data (Rated)

Rated voltage (V)	12
No-Load Speed (rpm)	38500 ± 10%
No-Load Current (A)	70 ± 50%
Rated speed (rpm)	25500 ± 10%
Rated torque (mNm)	0.85
Rated current(A)	0.5 ± 50%
Stall torque(mNm)	3.5 ± 7%
Stall current(A)	1.65 ± 20%
Max. efficiency(%)	67 ± 7%

Motor Constant (Rated)

Phase-to-Phase Resistance (Ω)	8.4 ± 10%
Phase-to-Phase inductance (mH)	0.05 ± 10%
Torque constant (mNm/A)	2.22 ± 20%
Speed constant (rpm/V)	3155 ± 20%
Speed/torque gradient (rpm/mNm)	11000 ± 20%
Mechanical time constant (ms)	2.87 ± 20%
Rotor inertia (gcm ²)	0.024 ± 20%

Thermal Data

Thermal resistance housing-ambient (K/W)	56.6
Thermal resistance winding-housing (K/W)	11.5
Thermal time constant winding (s)	3.7
Thermal time constant motor (s)	120
Ambient temperature (°C)	-20 ~ +100
Max. winding temperature (°C)	125

Mechanical Data (Ball Bearing)

Max. allowable speed (rpm)	40 000
Max. axial play (mm)	< 0.15 N 0 > 0.15 N 0.06 (max)
Radial play	preloaded
Max. axial load dynamic(N)	2
Max. force for press fits (static) (N)	10
Max. radial load (2 mm from flange) (N)	5

Note: Specifications can be customized per customer requirements.

Terminal Type

Molex 52745-1297

Note: Specifications can be customized per customer requirements.

Terminal Definition

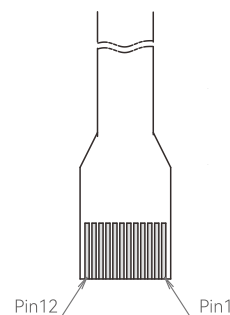

pin 1	Motor Winding 3
pin 2	Motor Winding 2
pin 3	Motor Winding 1
pin 4	Grounding
pin 5	VHall (3.3-24 VDC)
pin 6	Hall sensor 3
pin 7	Hall sensor 2
pin 8	Hall sensor 1
pin 9	None
pin 10	None
pin 11	None
pin 12	None